

- NOTES:
1. GEAR RATIO : 6.09:1
 2. LUBRICANT : SHIPPED WITHOUT OIL
 3. HARDWARE SHIPPED IN SEPARATE PACKAGE.
- CONTENTS INCLUDE : (1) BOLT, (2) KEYS, (1) NPT MAG PLUG,
(1) NPT PLUG, & (1) 5 PSI RELIEF PLUG W/ BUSHING

REV		ECN	REVISIONS	DATE	APPROVED
A			PRODUCTION RELEASE	10/26/06	F. WARE

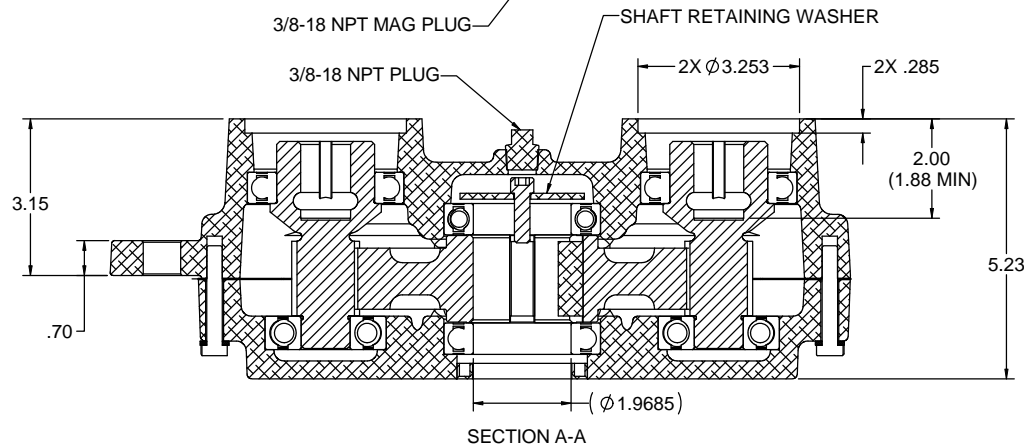
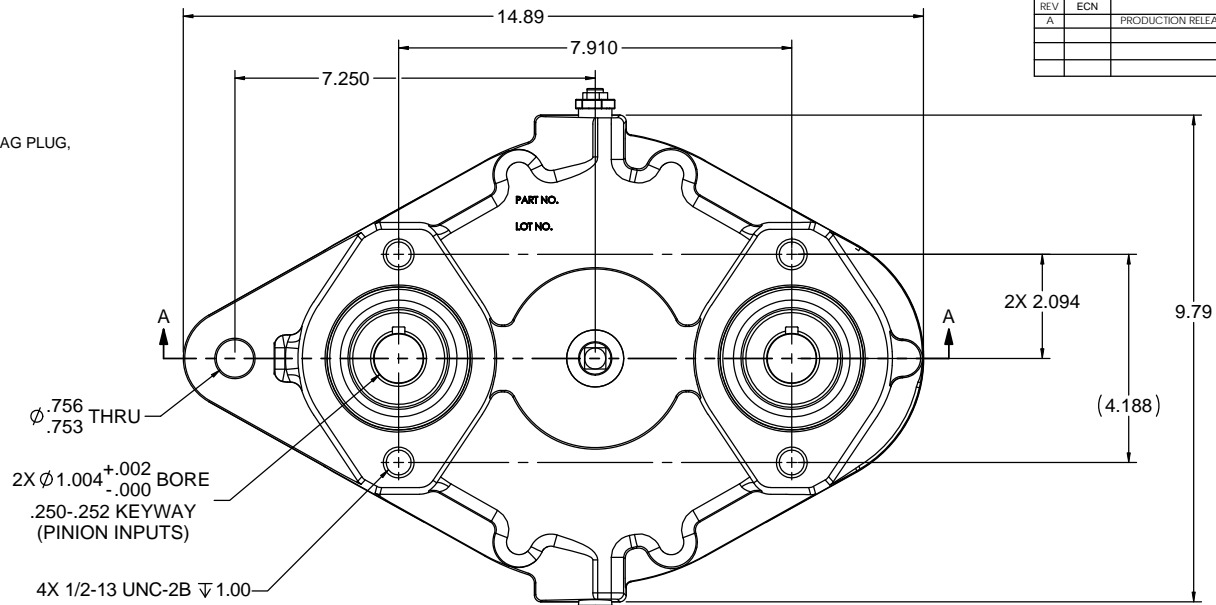

MATERIAL		UNLESS OTHERWISE NOTED		SUPERIOR GEARBOX COMPANY																					
-		DIMENSIONS ARE IN INCHES		P.O. BOX 645 STOCKTON, MO 65785																					
THIS DRAWING CONTAINS INFORMATION THAT IS PROPRIETARY & CONFIDENTIAL AND THE EXCLUSIVE PROPERTY OF SUPERIOR GEARBOX COMPANY AND MAY NOT BE REPRODUCED, USED OR DISCLOSED WITHOUT WRITTEN PERMISSION OF THE OWNER.		ALL EXTERNAL DIMENSIONS ARE NOMINAL AND DO NOT REPRESENT TOLERANCES. FOR SPECIFIC TOLERANCES ON EXTERNAL DIMENSIONS PLEASE CONTACT YOUR SUPERIOR GEARBOX COMPANY REPRESENTATIVE.		<table border="1"> <tr> <td>DPTR</td> <td>DATE</td> </tr> <tr> <td>J. CLARK</td> <td>06/20/06</td> </tr> <tr> <td>CHKR</td> <td>DATE</td> </tr> <tr> <td>F. WARE</td> <td>10/26/06</td> </tr> <tr> <td>ENGR</td> <td>DATE</td> </tr> <tr> <td>-</td> <td>-</td> </tr> <tr> <td>MFG</td> <td>DATE</td> </tr> <tr> <td>GC</td> <td>DATE</td> </tr> <tr> <td>-</td> <td>-</td> </tr> <tr> <td>DATE</td> <td></td> </tr> </table>		DPTR	DATE	J. CLARK	06/20/06	CHKR	DATE	F. WARE	10/26/06	ENGR	DATE	-	-	MFG	DATE	GC	DATE	-	-	DATE	
DPTR	DATE																								
J. CLARK	06/20/06																								
CHKR	DATE																								
F. WARE	10/26/06																								
ENGR	DATE																								
-	-																								
MFG	DATE																								
GC	DATE																								
-	-																								
DATE																									
		-INTERPRET DIMENSIONS AND TOLERANCES IN ACCORDANCE WITH ASME Y14.5M-1994 -REMOVE ALL BURRS AND BREAK SHARP EDGES -MACHINED SURFACES SHALL BE 125 μ IN -THREAD DEPTH CALLOUTS INDICATE DEPTH OF FULL THREADS -DIMENSIONAL LIMITS APPLY AFTER FINISH OR HEAT TREAT.		GEARBOX, MODEL IP39 SIZE PART NO. QTIP39-9JOX-G0313 REV A SCALE 1:1 DO NOT SCALE DRAWING SHEET 1 OF 1 (QT4896)																					